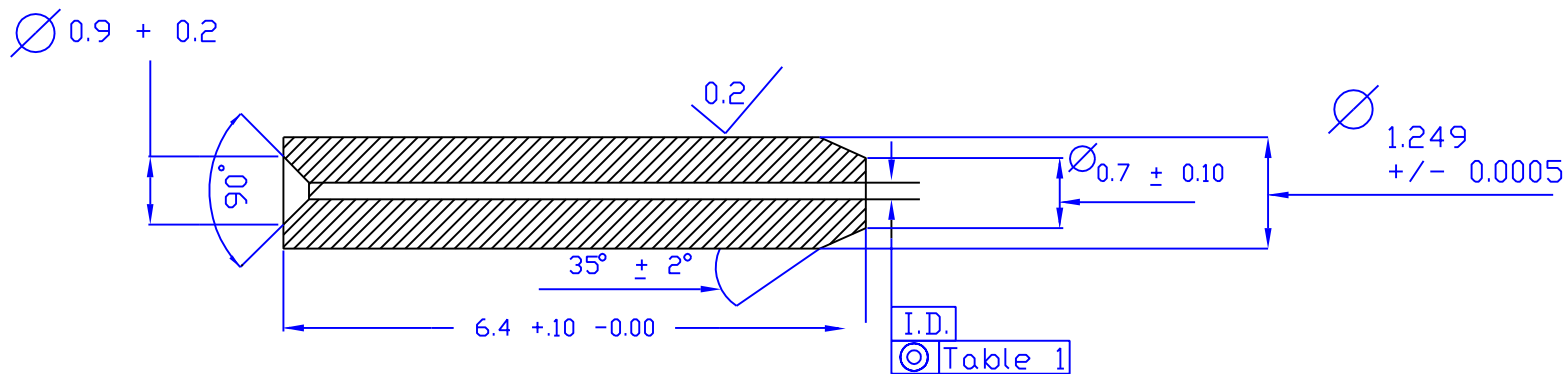

TABLE 1 INSIDE DIAMETER

-XXXX	I.D.	Min	Max	Concentricity
1260	0.1260	0.1260	0.130	<0.004
1270	0.1270	0.1270	0.131	<0.004
1400	0.1400	0.1400	0.145	<0.010
1440	0.1440	0.1440	0.149	<0.010
2000	0.2600	0.2600	0.270	<0.020
2300	0.2300	0.2300	0.240	<0.020
2400	0.2400	0.2400	0.250	<0.020
2450	0.2450	0.2450	0.255	<0.020
2500	0.2500	0.2500	0.260	<0.020
2600	0.2600	0.2600	0.270	<0.020
2700	0.2700	0.2700	0.280	<0.020
3000	0.3000	0.3000	0.310	<0.020
3300	0.3300	0.3300	0.340	<0.020

Revisions			
REV	DESCRIPTION	Date	Approved
00	Production release	02/21/04	RP
01	Changed Specifications	08/28/12	RP



Intellectual Property of Precision Fiber Products, INC. DO NOT duplicate. Return copies upon completion	Precision Fiber Products, Inc		
	MM LC Stick Ferrule		
U.S. +/- 0.1mm	Size:	DWG NO. MM-FER2007C-XXXX	REV 01
MATL: Ceramic Zircona (ZrO ₂)	Scale:	07/31/2007	Sheet 1 of 1